

## **Cemetery Rules and Regulations**

**for**

## **Holy Trinity Greek Orthodox Cemetery**

**Committee Revised:** 23 March, 2003  
**Council Approved:** 27 March, 2003

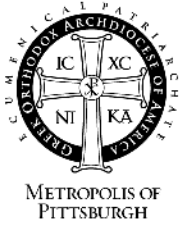

# HOLY TRINITY GREEK ORTHODOX CEMETERY

## SAINT GEORGE GREEK ORTHODOX CHAPEL



Location: 8941 Ringeisen Road, Allison Park, PA  
Mailing Address: Holy Trinity Church, 302 W. North Avenue, Pittsburgh, PA 15212-4626  
Reverend Father John Touloumes, *Economos* / William J. Fiedler Jr., *Cemetery Chairman*

### GENERAL

1. The Holy Trinity Greek Orthodox Community of 302 West North Avenue, Pittsburgh, Pa. is the sole owner and titleholder of all land hereby known as the Cemetery. This land has been dedicated by our Church and it is intended that it be used, into perpetuity, as the final resting-place of our deceased loved ones.
2. Accordingly, the land has been surveyed and mapped to provide space for this purpose. Orthodox Christians and their non-Orthodox Christian spouses & family members may purchase the Right Of Burial in specified plots or graves. These rights shall be inviolate.
3. In the interest of uniformity and in the interest of maintaining the order and dignity of our cemetery, those who purchase the Right Of Burial in our cemetery are subject to the rules and regulations herein as approved by the Parish Council of the Community.
4. Reciprocity: Items in place, excluding plantings, that become non-conforming due to revisions to these rules will not require altering to come into compliance.

### CANONICAL

1. Burials will adhere to the canons of the Greek Orthodox Church.
2. In accordance with the canonical regulations referred to above, the internment and burial of cremated individuals is strictly prohibited.

### GRAVE LOTS

1. Lots: Location of grave lots has been surveyed and is shown on plans that are available in the Community office. See Plates A & B.
  - a. Areas available for single graves, double graves, triple graves and family plots of 6, 12 and 24 graves may be designated.
  - b. In addition, groups or societies may arrange with the committee to set aside an entire area for the exclusive use of their membership.
  - c. Vaults: Vaults are required in all graves.

### GRAVE PRICES

1. The Right Of Burial is hereby defined as the right of an individual to be buried in a designated space and does not include the purchase of the physical land therein. Ownership of the land is retained by the Holy Trinity Greek Orthodox Community.
2. Prices are for the Right Of Burial in grave lot(s) and do not include opening and closing fees, memorial stones or any other markers. Contact Church Office for latest Right Of Burial prices.
3. Grave Openings: The physical opening of graves will only be performed by the Cemetery's approved Grave Contractor at a separate and approved cost.

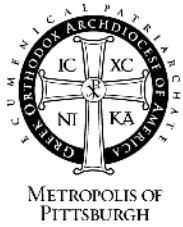

# HOLY TRINITY GREEK ORTHODOX CEMETERY

## SAINT GEORGE GREEK ORTHODOX CHAPEL



Location: 8941 Ringeisen Road, Allison Park, PA  
Mailing Address: Holy Trinity Church, 302 W. North Avenue, Pittsburgh, PA 15212-4626  
Reverend Father John Touloumes, *Economos* / William J. Fiedler Jr., *Cemetery Chairman*

4. Reserved Graves: Unpaid graves may not be "Reserved" or "Held" in the name of a family or family member. Families that have graves that are shown as "Reserved" or "Held" in old documents will be given first opportunity to purchase the Right Of Burial when spaces come into question.
5. Proof of Ownership: Deeds or receipts must be presented for verification of ownership of pre-bought Right Of Burials. The Cemetery cannot accept "word of mouth" as verification.
6. Resale of Rights: The Cemetery will repurchase, from the legal owner upon proof of ownership, the Deed to Right of Burial at the face value of the original purchase.

### MEMORIAL STONES AND MARKERS

1. Memorial Stones, Grave Markers and Monuments: Memorial markers must be built and erected according to the following specifications and with proper concrete foundations to support all stonework and markers.
  - a. Materials: Markers must be of stone or non-ferrous metal (i.e. bronze). The use of wood, ferrous metal, concrete or artificial stone of any kind is not permitted as permanent grave markers.
  - b. Location:
    - Vertical Stone: At head of graves (See Plate C).
    - Flush: At head of graves or when both a vertical and a flush marker exist, at the foot of grave and flush with the ground (See Plate D).
    - No stone or marker is permitted to be erected on or extend onto graves where the Right Of Burial has not been purchased.
  - c. Vertical Marker Size:
    - Single Grave: Maximum of two (2) feet wide and two (2) feet high.
    - Double Graves: Maximum of four (4) feet wide and three (3) feet high.
    - Three Graves or larger: Maximum of six (6) feet wide and four (4) feet high.
  - d. Flush Markers Size:
    - Single Grave: Maximum of thirty (30) inches wide and eighteen (18) inches in length.
    - No "pillow" type stone or marker is permitted unless it conforms to the flush marker location above.
  - e. Special monuments will be permitted only if sufficient land is purchased to allow proper clearances and approval is secured from the Cemetery Committee prior to erection.
  - f. Non-conformance: Stones or markers erected without approval and in non-conformance to the above regulations must be removed and corrected at the family's expense.

### DECORATIONS

1. Perennial or annual flowers may be planted within one foot (12 inches) in front of the headstone and may not extend beyond the width of the headstone.
2. Continuously growing deciduous trees, evergreens or bushes are prohibited within gravesites.
2. Placement of urns, vases, wooden markers, ornaments, glass, chinaware, ceramics, plastic flowers, open top candles and wreaths is prohibited.
3. Vigil lights (candles) are permitted only if they are totally enclosed and have a top cover.

### MAINTAINENCE OF CEMETERY AND GRAVES

1. Families of the interred are responsible for maintaining grass, headstones, markers and for restricting planting to within the designated area.
2. The Cemetery will provide topsoil, on-site, to permit proper seeding of graves by the owners or families. Only grass is permitted to cover the grave(s).

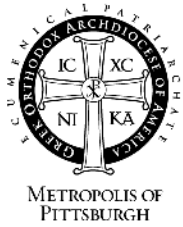

# HOLY TRINITY GREEK ORTHODOX CEMETERY

## SAINT GEORGE GREEK ORTHODOX CHAPEL

---

Location: 8941 Ringeisen Road, Allison Park, PA  
Mailing Address: Holy Trinity Church, 302 W. North Avenue, Pittsburgh, PA 15212-4626  
Reverend Father John Touloumes, *Economos* / William J. Fiedler Jr., *Cemetery Chairman*

---



3. The Cemetery will be responsible for cutting the grass and for the overall appearance of the cemetery. Care will be exercised to avoid disturbing permitted plantings described above.
4. The Cemetery will not be responsible for the upkeep of headstones, markers, and stonework or held liable for damage due to vandalism, improper installation or weather deterioration.
5. Emergency corrective repairs required to prohibit further damage to stones, markers and adjacent graves will be performed by the Cemetery and costs billed to the family of the interred.
6. Rubbish, candles, wreaths, flowers and other materials must only be discarded in the provided rubbish bin.
7. Respect and do not disturb the property of others.

### EXECUTIVE

1. The Cemetery Committee reserves the right to amend, repeal or expand these Rules and Regulations with the consent and approval of the Parish Council.

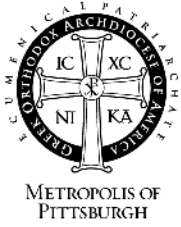

# HOLY TRINITY GREEK ORTHODOX CEMETERY

## SAINT GEORGE GREEK ORTHODOX CHAPEL



Location: 8941 Ringeisen Road, Allison Park, PA  
 Mailing Address: Holy Trinity Church, 302 W. North Avenue, Pittsburgh, PA 15212-4626  
 Reverend Father John Touloumes, *Economos* / William J. Fiedler Jr., *Cemetery Chairman*

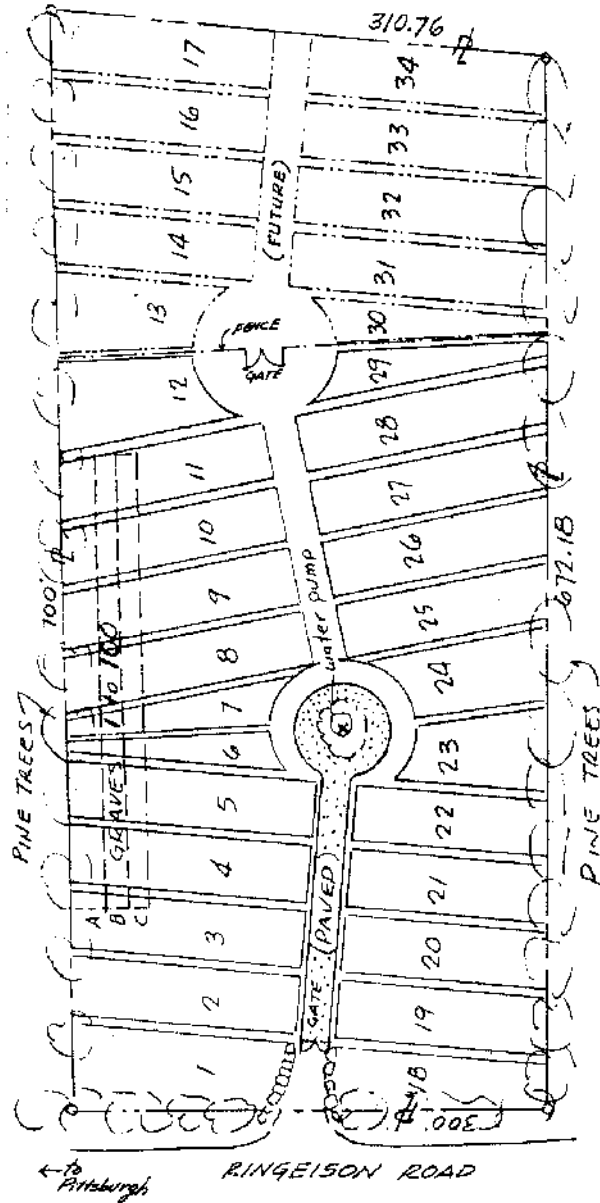

HOLY TRINITY G.O. CEMETARY  
 MCCANDLESS TWP., PA

### PLATE A

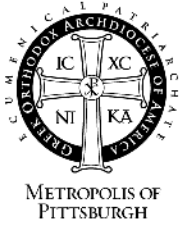

# HOLY TRINITY GREEK ORTHODOX CEMETERY

## SAINT GEORGE GREEK ORTHODOX CHAPEL

Location: 8941 Ringeisen Road, Allison Park, PA  
 Mailing Address: Holy Trinity Church, 302 W. North Avenue, Pittsburgh, PA 15212-4626  
 Reverend Father John Touloumes, *Economos* / William J. Fiedler Jr., *Cemetery Chairman*

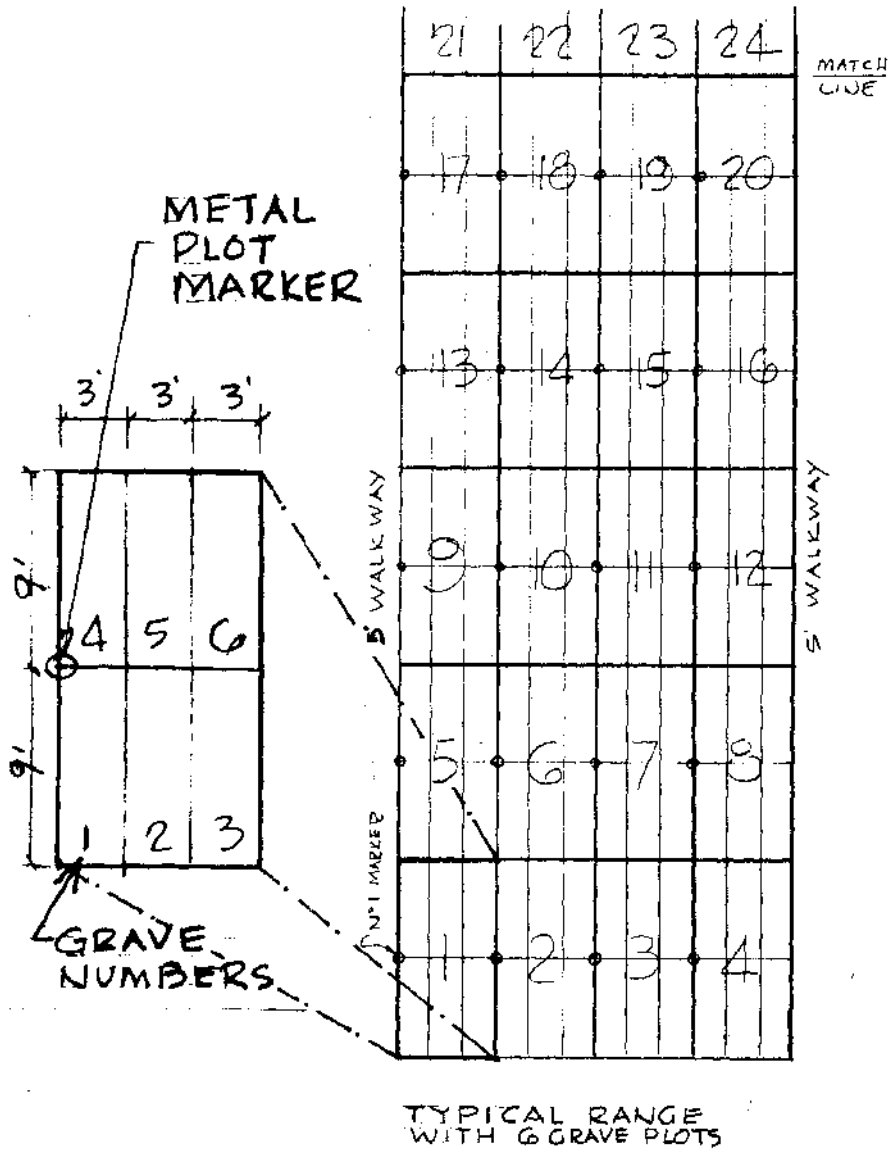

### PLATE B

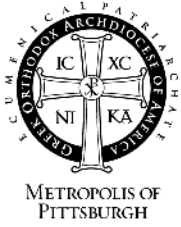

# HOLY TRINITY GREEK ORTHODOX CEMETERY

## SAINT GEORGE GREEK ORTHODOX CHAPEL



Location: 8941 Ringeisen Road, Allison Park, PA  
 Mailing Address: Holy Trinity Church, 302 W. North Avenue, Pittsburgh, PA 15212-4626  
 Reverend Father John Touloumes, *Economos* / William J. Fiedler Jr., *Cemetery Chairman*

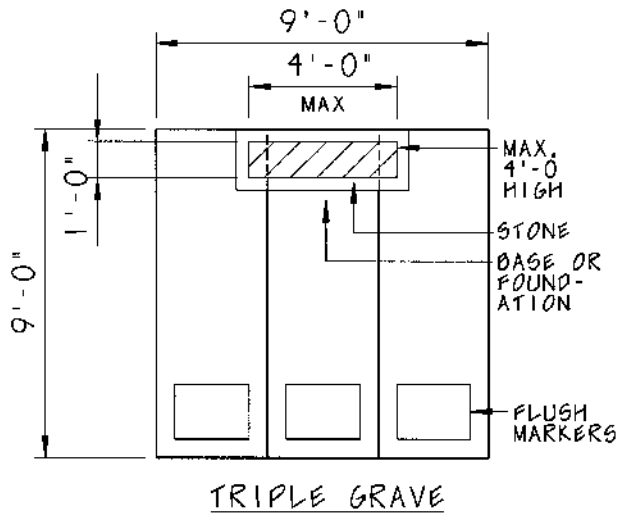
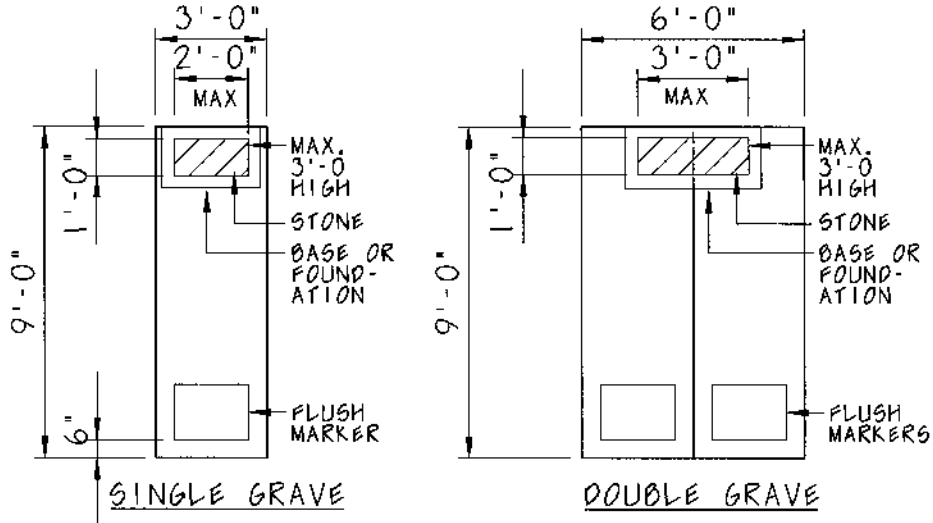

- NOTES:
1. ERECT MEMORIAL STONES ONLY AT HEAD OF GRAVES
  2. STONE FOUNDATIONS ARE TO BE BELOW FROST DEPTH AND SUFFICIENT TO PROVIDE STABLE SUPPORT.
  3. FOUNDATIONS AND STONE BASES ARE NOT TO PROTRUDE BEYOND EDGES OF GRAVES PURCHASED.

### PLATE C

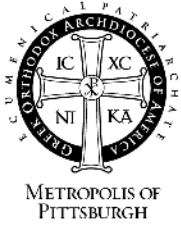

# HOLY TRINITY GREEK ORTHODOX CEMETERY

## SAINT GEORGE GREEK ORTHODOX CHAPEL

Location: 8941 Ringeisen Road, Allison Park, PA  
Mailing Address: Holy Trinity Church, 302 W. North Avenue, Pittsburgh, PA 15212-4626  
Reverend Father John Touloumes, *Economos* / William J. Fiedler Jr., *Cemetery Chairman*

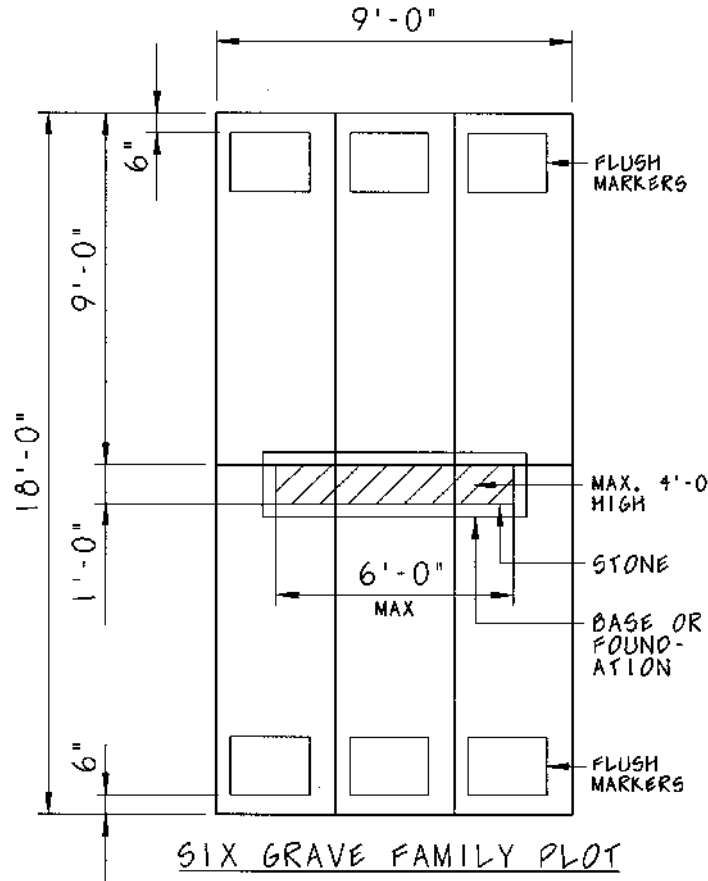

### PLATE D